



# WIRELESS LAN INTERFACE MAIN UNIT INSTALLATION MANUAL

- This INSTALLATION MANUAL can also be viewed on the home page of MITSUBISHI HEAVY INDUSTRIES THERMAL SYSTEMS, LTD.
- Please download USER'S MANUAL (including the guarantee form) via the QR code or from the home page described later.





**Safety precautions** Please read these safety precautions carefully before installing and using this product.

- Be sure to follow these precautions because they describe important safety-related information.

 <b>WARNING</b>	Failure to follow warnings may cause serious consequences such as death or severe injury.
 <b>CAUTION</b>	Failure to follow cautions may cause injury and/or property damage. Depending on the situation, failure to follow cautions may lead to serious consequences.

- The "graphic symbols" in this document have the following meanings.

	Prohibited.
	Be sure to follow instructions.

- After the installation work is completed, check the installation according to the installation work check items. Request your customer to keep this installation manual at the customer's site.

## **WARNING**



- Do not bundle, roll, or step on connection cables to prevent cables from becoming deformed.  
(Deformation may cause heat generation, fire, or electric shocks due to loose connection, insulation failure, current exceeding the allowable limit, etc.)
- Do not install this product near automatic control equipment such as an automatic door or fire-alarm device.  
(Such improper installation may cause an accident due to malfunction of equipment.)
- Do not install this product at a location in a hospital, etc. where the use of wireless devices is prohibited.  
(Such improper installation may cause malfunction of medical equipment due to a wireless device.)
- Do not use this product near a person with a cardiac pacemaker or implanted defibrillator.  
(Such improper use may cause malfunction of a medical device.)
- Do not disassemble, modify, or repair this product.  
(Such an activity may cause an electric shock, fire, or any injury.)



- For installation work, request the sales outlet for the product or an authorised dealer to install the product.  
(Improper installation may cause a water leakage, electric shock, or fire.)

## **WARNING**



- In the installation work, install the product securely according to this installation manual, and be sure to use accessories and specified parts for installation.  
(Improper installation may cause a water leakage, electric shock, or fire.)
- The electrical engineering work must be performed by a qualified electrical worker according to the technical standards concerning electrical equipment, interior wiring regulation, and installation manual.  
(Improper work may cause an electric shock or fire.)
- For wiring, use the specified cable, and connect the cable securely. Then, fix the terminal connection part securely to prevent external force from being transmitted to the connection part through the cable.  
(Improper connection may cause any failure, heat generation, or fire.)
- Before installing the wireless interface, ensure the main electrical power supply is OFF.  
(Installing the wireless interface with the main electrical power supply ON, could cause damage to the wireless interface.)
- When you unplug the connection cable, hold the connector to unplug the cable.  
(Improper work may cause an electric shock or fire.)

## **WARNING**



- This appliance is not intended for use by persons (including Children) with reduced physical, sensory or mental capabilities, or lack of experience and knowledge, unless they have been given supervision or instruction concerning use of the appliance by a person responsible for their safety.
- This appliance can be used by children aged from 8 years and above and persons with reduced physical, sensory or mental capabilities or lack of experience and knowledge if they have been given supervision or instruction concerning use of the appliance in a safe way and understand the hazards involved.
- Children shall not play with the appliance.
- Cleaning and user maintenance shall not be made by children without supervision.
- Children should be supervised to ensure that they do not play with the appliance.
- If cable is damaged, it must be replaced by the manufacturer, its service agent or a similarly qualified person in order to avoid a hazard.



## CAUTION



- Do not use the product near another wireless device, microwave, cordless phone, fax machine, etc.  
(Improper use may cause malfunction.)



- To prevent any failure due to electrical discharge, touch your hand with metal around you to remove static electricity from your body before you touch this product.  
(Improper operation may cause any failure.)
- Be sure to keep dry because the product is not waterproof.  
(Improper connection may cause any failure, heat generation, or fire.)

# 1. Cautions for installation

- Do not mount the holder and interface in any location, only mount the interface in the dedicated location and direction of the indoor unit.
- Fix the holder on the indoor unit securely with the attached screws by hand. If using an electric driver, it may cause deformation.
- Install the connection cable securely by sliding the interface in the direction of the arrow, this will prevent the cable from being trapped in the holder.
- Never extend the connection cable, as this may cause incorrect operation of the interface.
- Record SSID and KEY (Password) before installation (these may be required when setting up the connection with the smartphone application).

## <Mount to indoor unit>

Accessories supplied with this product		
Check the accessories supplied with this product.		
Symbol	Part name	Quantity
A	Holder	1
B	Holder mounting screw	2
C	Interface	1
D	Installation manual (this document)	1

SSID: \_\_\_\_\_  
KEY: \_\_\_\_\_

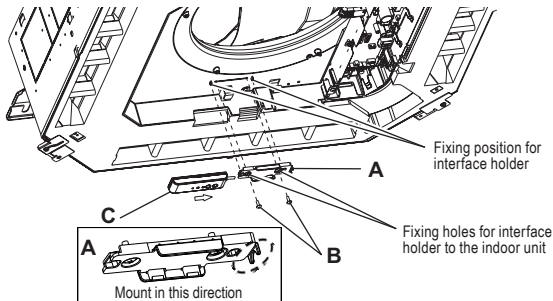

## 2. Connecting this product with the indoor unit

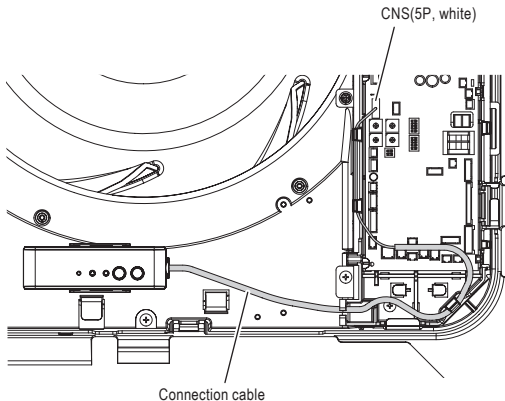

Connect the indoor unit connection cable to the indoor control printed-circuit board.

- Connect the connector of the indoor unit connection cable to the terminal (CNS) on the indoor control board by installing the cable along the wiring route.
- Securely connect the connector of the indoor connection cable to the CNS terminal on the indoor control board.
- About the handling of the connection cable  
If the connection cable is too long, the redundant cable section should be stored loosely in a space.

## After the installation work is completed, be sure to check the following.

### Installation work check items

- Is the holder fixed securely?
- Is the cable trapped? Is the connection cable under a load?
- Is the connector connected properly and securely?
- Did you forget to tighten a screw on the main body of the indoor unit?
- Turn ON the power to the indoor unit. After that, do the Communication LED and Running LED become ON for about 10 seconds and then OFF? (If the Communication LED and Running LED blink alternately at intervals of 10 seconds, check the connection.)
- Did you record SSID and KEY (password) in the installation manual?

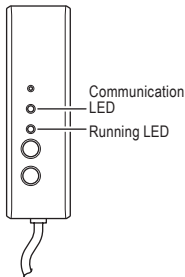

Normal:

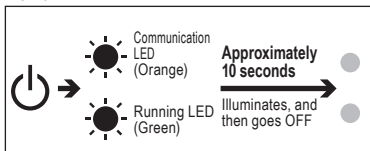

Abnormal:

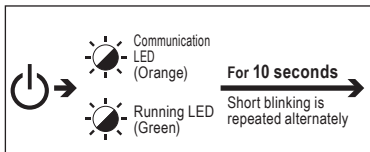

- Did you explain the cautions in the user's manual to the customer?
- Did you pass the installation manual to your customer and request the customer to thoroughly read and store the manual?

\* If you have any question on the installation, please contact us at the URL on the last page for inquiry.



## Notes for users

- Before using the product, the user needs to install the dedicated application.  
The user needs to install the latest version smartphone application and then set up a connection with the interface. Set up a connection with the interface according to the user's manual downloaded via the following QR code or from the URL.
- The application is free. Communications charges are applied to downloading and operation.
- The application name "Smart M-Air" and download service names "Google Play" and "App Store" may be changed in the future.

How to install the "Smart M-Air" smartphone application	
<b>For Android</b> <ol style="list-style-type: none"><li>1. Open [Google Play].</li><li>2. Search for [Smart M-Air].</li><li>3. Install the application according to the instructions on the screen.</li></ol>	<b>For iOS (iPhone)</b> <ol style="list-style-type: none"><li>1. Open [App Store].</li><li>2. Search for [Smart M-Air].</li><li>3. Install the application according to the instructions on the screen.</li></ol>
<b>User's Manual</b> <p>Refer to the home page of MITSUBISHI HEAVY INDUSTRIES THERMAL SYSTEMS, LTD.</p> <p><a href="http://www.mhi-mth.co.jp/en/products/detail/air-conditioner_users_manual.html">http://www.mhi-mth.co.jp/en/products/detail/air-conditioner_users_manual.html</a></p>	

- CE Marking  
Refer to the home page of MITSUBISHI HEAVY INDUSTRIES THERMAL SYSTEMS, LTD.  
[https://www.mhi-mth.co.jp/en/technology/ce\\_marking.php](https://www.mhi-mth.co.jp/en/technology/ce_marking.php)

---

**MITSUBISHI HEAVY INDUSTRIES THERMAL SYSTEMS, LTD.**

2-3, Marunouchi 3-chome, Chiyoda-ku, Tokyo, 100-8332, Japan (Japonya)  
<http://www.mhi-mth.co.jp/en/>

**MITSUBISHI HEAVY INDUSTRIES AIR-CONDITIONING EUROPE, LTD.**

5 The Square, Stockley Park, Uxbridge, Middlesex, UB11 1ET, United Kingdom  
Tel : +44-333-207-4072  
Fax: +44-333-207-4089  
<http://www.mhiae.com/>

**MHIAE SERVICES B.V.**

(Wholly-owned subsidiary of MITSUBISHI HEAVY INDUSTRIES  
AIR-CONDITIONING EUROPE, LTD.)  
Herikerbergweg 238, Luna Arena, 1101 CM Amsterdam, Netherlands  
P.O.Box 23393 1100 DW Amsterdam, Netherlands  
Tel : +31-20-406-4535  
<http://www.mhiaeservices.com/>

**MITSUBISHI HEAVY INDUSTRIES AIR-CONDITIONERS AUSTRALIA, PTY. LTD.**

Block E, 391 Park Road, Regents Park, NSW, 2143 PO BOX 3167, Regents Park,  
NSW, 2143  
Tel : +61-2-8774-7500  
Fax: +61-2-8774-7501  
<https://www.mhiao.com.au>